



TESTING & INTEGRATION GROUP

SOLUTION GUIDE

High speed streaming service solution with Real Helix Servers

**INTRODUCTION ..... 2**

**SOLUTION DETAILS ..... 3**

**HOW IT WORKS ..... 3**

    IMPORTANT NOTES: ..... 4

    SOFTWARE AND HARDWARE ..... 4

    TESTED NETWORK OVERVIEW ..... 5

**CONFIGURATION ..... 6**

    RADWARE DEVICES ..... 6

*WSD NP CENTRAL SITE* ..... 6

*WSD REMOTE SITE* ..... 7

    MEDIA SERVERS ..... 8

*REAL HELIX SERVERS* ..... 8

    CACHE / SPLITTING SERVERS ..... 9

*NETAPP NETCACHE 1105 SERVERS* ..... 9

*MEDIA CLIENTS* ..... 9

**TECHNICAL SUPPORT ..... 9**

TECHNICAL SOLUTION GUIDE  
AUTHOR: Elad Kurzweil  
DATE: Monday, February 28, 2005  
Version: 1.0

## Introduction

In virtually every business vertical, streaming media has become an application that is deployed to deliver a service, explain a product, market a service or perform some other needed function that plays core role in the functioning of the company. Perhaps one of the earliest & most pervasive adopters of streaming media has been the carrier and service provider. By offering streaming media and CDN service, carriers and ISPs have opened up a whole new world of services offerings, from news clips to multimedia products such as VOIP to gaming options to their users.

There are several important challenges that companies face in the delivery of streaming content and successfully continue to maintain their online operations:

The **availability** of applications is essential to the core business of the carrier/ISP. Failures and degradation of those mission critical applications can impact business operation by impacting sales and revenues. There can be many factors that undermine the 100% availability requirement.

Because of the explosive growth and reliance by businesses on their networked applications, the demand for increased throughput and performance continues to grow. As more applications become "digitized" and "heavier", the requirements to maintain the **performance** of mission critical applications becomes critical.

The majority of attacks that hit networks today are application based. Today, there is a clear and present need to address application based attacks that existing security tools do not address. The need for **security** ultimately can eliminate downtime across the network.

Radware develops new services and tools, in order to provide the carrier/ISP with innovative solutions for the following needs:

- The carrier must offer new and diverse services to generate additional revenues from the client infrastructure while developing a way of differentiating their service offering against their competition
- The carrier must penetrate new customers, especially medium-to-large-sized enterprises
- The carrier must be able to sell the solution based on its advantages. Cost should not be the cornerstone of a marketable solution

Radware addresses these needs by providing a comprehensive set of services across all application needs through its SynApps architecture. This architecture is built on Radware's advanced application switch platform, thus achieving the highest standards in performance, scalability, security and throughput. By using advanced health monitoring techniques, integrated local and global health monitoring and patented proximity detection technologies, carriers/ISPs can deliver unparalleled streaming content. With Radware solution the carrier/ISP can position itself as a provider of "cutting edge" solutions. Specifically the carrier/ISP should be known for ensuring availability, superior performance and absolute security to the end-user. This paper addresses the configuration and management of CDN for streaming media and how the carrier/ISP or business can maintain the **Availability**, **Performance** and **Security** of this service across the network.

## Solution Details

The document presents a global Media solution for Corporate and ISP's that want to use Streaming services and get the best availability and redundancy according to the client destination.

This solution has 2 sites that are sitting in different location. The main site has a WSD-NP/DS that load balance Real Helix servers and does redirect to other sites via proximity mechanism which allows the WSD to find out where the client come from and redirect the traffic to the client closer site. The remote site is controlled by WSD-Pro which load balance NetCache servers. Each NetCache server is acting as a Real Helix server and a Cache server that splits the video from the actual Main site via only 1 stream that are splited to many streams. One of the biggest advantages of this integration is that the client can be over the world and he will redirect to the closet site to him and get the best performance by not limiting the traffic to pass through the WSD.

## How it works

The client point IP is 10.1.1.100 (global VIP IP) the WSD NP (Global Site) will choose according to the Proximity mechanism the right site and the right server according to Latency, Hops and Server availability. In the [Tested network overview](#) diagram you can see that the client is closer to the Remote sit, in this case the WSD-NP in the main site will choose automatically the Remote site because it's the closet site to the client. At this example we used Local Triangulation to get the highest performance from the Real Helix servers, NetCache servers and WSD by not passing the returning traffic through the WSD. This way the WSD on each site is handling only the client requests and not the heavy load of traffic that comes back to the client.

## Important Notes:

- **Always use Regular session mode in the farm when using Real Helix servers. The live stream changes the source ports in the middle of a session.**
- **The distributed NetCache appliances to get a live feed from the actual Real Helix servers using farm 10.1.1.200. When the NetCache server doesn't have the content in the cache it will need to get the feed from the Real Helix server.**
- **There is no limitation for WSD remote sites.**

## Software and Hardware

The following is a list of hardware and Multimedia software tested to verify the interoperability of the presented solution:

Radware's WSD NP v.7.54

Radware's WSD Pro v.7.54

Streaming Client: Windows media v6.4, 8.0, 9.0 and 10.0

Streaming Server: Real Helix Server v.9.0

Streaming Splitter and Cache : Network Appliance NetCache server C1105 v 5.6.b8

### Tested network overview

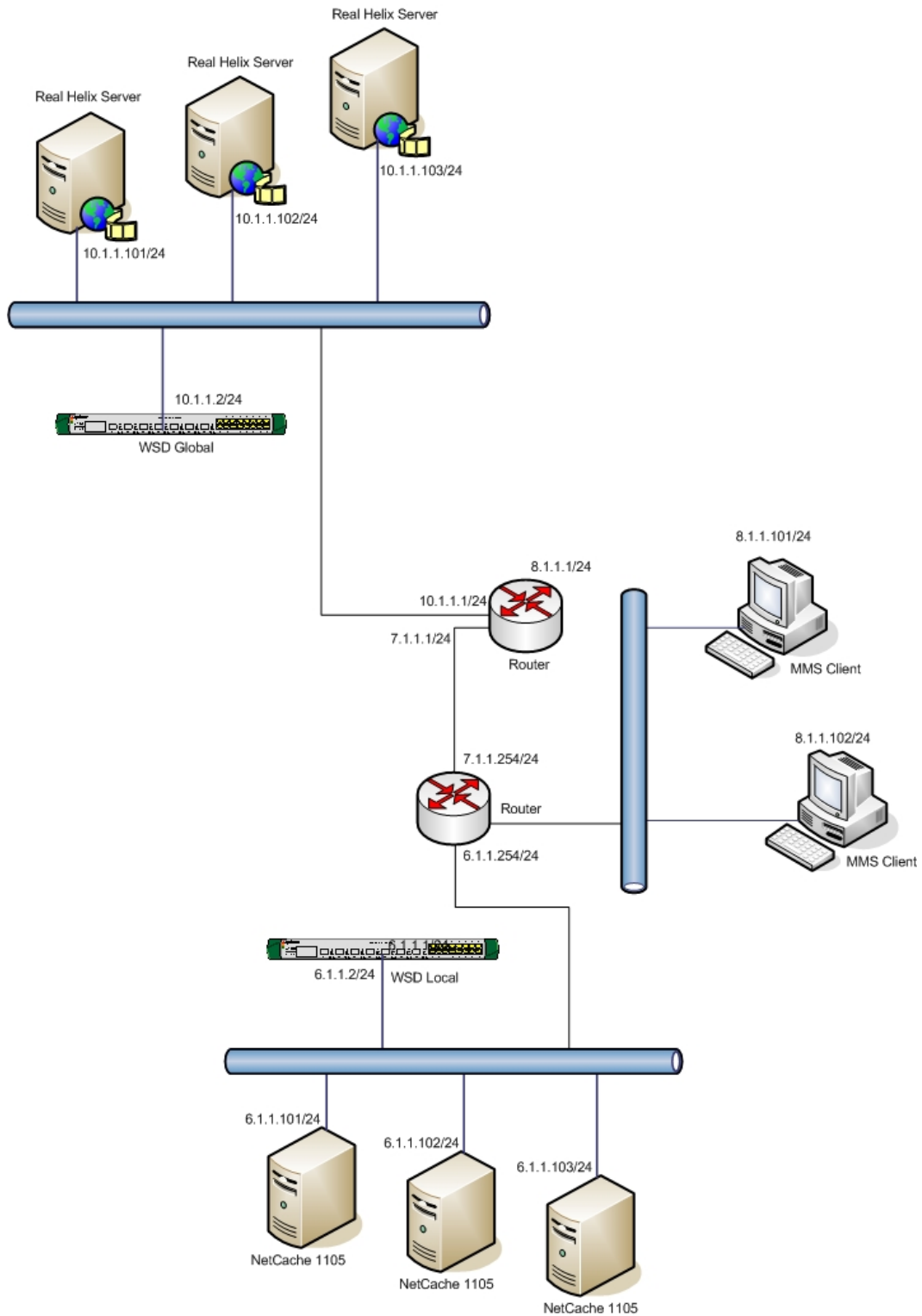

**Network Diagram**

## Configuration

### Radware Devices

#### WSD NP CENTRAL SITE

#### Network Configuration

- Create IP 10.1.1.2 on port 17
- Create default route to 10.1.1.1

#### WSD Configuration

- Create Farm 10.1.1.100 with this options
  - o Redirection mode – Triangulation
  - o Dispatch mode – Cyclic
  - o Session mode - Regular
- Create Farm 10.1.1.200 and leave all fields as default (this farm will be used for live feed from Real Helix servers to the NetCache servers)
- Add servers to Farm 10.1.1.100
  - o Add local server – 10.1.1.101 with Mode type- Local triangulation
  - o Add local server – 10.1.1.102 with Mode type- Local triangulation
  - o Add local server – 10.1.1.103 with Mode type- Local triangulation
  - o Add Remote server – 6.1.1.100 (this is the remote WSD Farm address) with mode type- Distributed WSD
- Add servers to Farm 10.1.1.200
  - o Add local server – 10.1.1.101 with Mode type- Local triangulation
  - o Add local server – 10.1.1.102 with Mode type- Local triangulation
  - o Add local server – 10.1.1.103 with Mode type- Local triangulation
- Enable the Proximity to Full Proximity in **WSD -> Proximity -> Parameters -> General**. For optimized load sharing on both sites you can play with the Hops weight (the number of hops between client and farms when determining proximity, The greater the number, the more distance (in hops) will figure in the determination), Latency Weight (the time between client and farms when determining proximity, The greater the number, the more the round trip time will figure in the determination) and Load Weight (the traffic between client and farms when determining proximity, The greater the number, the more the amount of traffic will figure in the determination); all fields numbers are between 1 to 100.

#### Health monitoring configuration

- Enable Health Monitoring for the device in **WSD -> Health Monitoring -> Global Parameters** and change the **Health Monitoring Status** to "Use health Monitoring".
- Define health checks in the **Health Monitoring -> Check Table** to check each of the Streaming Servers 10.1.1.101, 10.1.1.102, 10.1.1.103 and 6.1.1.100 using RTSP check.
- Bind the health checks to each Streaming Server in the **Health Monitoring -> Binding Table** (don't forget to bind farm 10.1.1.200 with the 3x Real Helix servers).

## WSD REMOTE SITE

### Network Configuration

- Create IP 6.1.1.1/24 on port 17
- Create Default GW to 6.1.1.254

### WSD Configuration

- Create Farm 6.1.1.100 with session mode – Regular mode, leave all fields as default
- Add Servers to farm 6.1.1.100
  - o Add local server – 6.1.1.101 with Mode type- Local triangulation
  - o Add local server – 6.1.1.102 with Mode type- Local triangulation
  - o Add local server – 6.1.1.103 with Mode type- Local triangulation
- Create LRP rule to enable the load reports to the NP WSD in **WSD -> Distributed System -> Report Configuration**
  - o Farm Address – 6.1.1.100
  - o Distributed Farm Address – 10.1.1.100
  - o Remote WSD Address - 10.1.1.2
  - o Mapped Farm Address – 6.1.1.15 (The IP address of the farm to which remote clients are redirected by the local WSD DS/NP device (used for the triangle redirection). This address is sent so remote devices will know which farm to access in case of redirection. Clients are considered clients of the distributed farm and not of the local farm)
  - o Leave all other fields as default

### Health monitoring configuration

- Enable Health Monitoring for the device in **WSD -> Health Monitoring -> Global Parameters** and change the **Health Monitoring Status** to “Use health Monitoring”.
- Define health checks in the **Health Monitoring -> Check Table** to check each of the Streaming Servers 6.1.1.101, 6.1.1.102 and 6.1.1.103 using RTSP check.
- Bind the health checks to each NetCache server in the **Health Monitoring -> Binding Table**.

## Media Servers

### REAL HELIX SERVERS

#### Network Configuration

- Create IP 10.1.1.101/24 for Server-1
- Create IP 10.1.1.102/24 for Server-2
- Create IP 10.1.1.103/24 for Server-3
- Create Default GW to 10.1.1.1 for all servers
- Add a Loopback adapter with IP 10.1.1.100/24 there is no need to remove a route like in old OS versions, when adding IP to the Loopback interface change the Metric to 50 instead of 1 (How to add the Loopback adapter please refer to this step by step link [http://www.window networking.com/articles\\_tutorials/Install-Microsoft-Loopback-adapter-Windows-XP.html](http://www.window networking.com/articles_tutorials/Install-Microsoft-Loopback-adapter-Windows-XP.html))
- Install the Real Helix server (to get more information please refer to [www.realnetworks.com](http://www.realnetworks.com)).

## Cache / Splitting Servers

### NETAPP NETCACHE 1105 SERVERS

#### Network Configuration

- Create IP 6.1.1.101/24 for Netcache-1
- Create IP 6.1.1.102/24 for Netcache-2
- Create IP 6.1.1.103/24 for Netcache-3
- Add default GW 6.1.1.1 to all Netcache servers
- Add a loopback adapter to the "lo" interface IP 10.1.1.100 (the command is "ifconfig lo alias 10.1.1.100 netmask 255.255.255.0)
- Enable the RTSP Streaming protocol support
- Enable the Streaming acceleration mode and add a rule that will point to the remote farm address IP 10.1.1.200 :
  - o Accelerator
    - IP Address - \*
    - Port Number - 554
    - Host Name - \*
    - Path Name - \*
  - o Streaming Server
    - IP Address – 10.1.1.200
    - Port Number – 554
    - Host Name - \*
    - Path Name - \*

### MEDIA CLIENTS

- Point the client to IP 10.1.1.100

## Technical Support

Radware offers technical support for all of its products through the Radware Certainty Support Program. Please refer to your Certainty Support contract, or the Radware Certainty Support Guide available at:

<http://www.radware.com/content/support/supportprogram/default.asp>.

For more information, please contact your Radware Sales representative or:

U.S. and Americas: (866) 234-5763

International: +972(3) 766-8666